

# HYB55A05 HYB55A05A

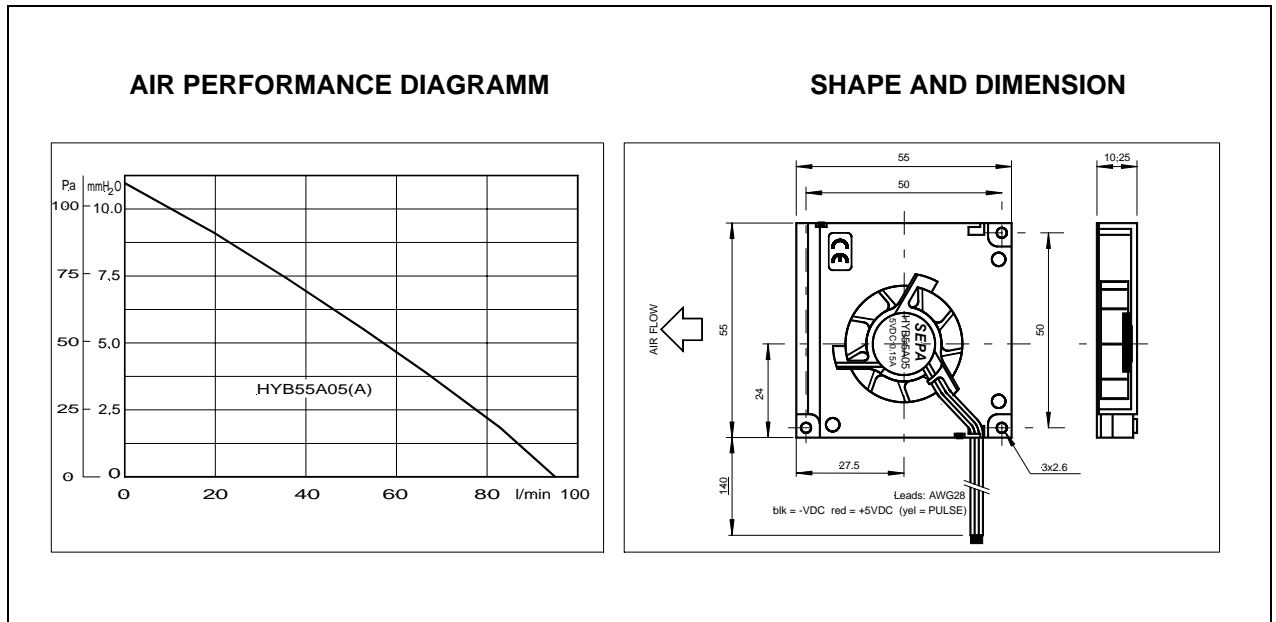

## HIGH RELIABILITY FAN

AUTOMOTIVE FAN



## PERFORMANCE

<b>CE</b>		<b>HYB55A05</b>	<b>HYB55A05A</b>
Operating Voltage	[V]	4.5 ... 5.0 ... 5.5	
Operating Current	[mA]	150	
Max. Start Current	[mA]	350	
Max. Air Flow	[l/min - m <sup>3</sup> /h]	95 – 5.7	
Max. Air Pressure	[mmH <sub>2</sub> O - Pa]	11 - 108	
Noise @ 1m (typ.)	[dB(A)]	31	
Operating Temperature	[°C]	-10/+60 (80)	
Rotor Speed	[RPM]	4500	
Life Expectancy @20°C	[L <sub>10</sub> /MTBF; h]	95000/280000	
Bearing System		ball bearings ZZ	
Weight	[g]	46	
Speed Sensor		-	2 pulses / rev
Packing Quantity	[PCs]	50-500	

This **SEPA**<sup>®</sup> turbo fan is suitable for industrial use and has a remarkable air flow performance despite its extremely small dimensions. Due to the linear air performance characteristic, the fan is applicable for different uses. Air intake could be on top or bottom, the outlet is on one side. It is permanently protected electrically against reverse polarity, blocking and thermal overloading. Due to the low rotor weight and precision balancing, it is virtually vibration-free. It is also insensitive to shock.

Further features of this fan are its extremely robust and torsionally rigid housing made from aluminium alloy, ball bearings with narrow tolerances, of special steel, polyester-based PCB (UL E44247) and absolute reliability due to 100% burn-in.

• **Alarm Signal (Optional)**

The **SEPA**® HYB55C05A includes a speed impulse output, which enables monitoring the correct function of the fan. An alarm-board is available on request.

The pulse is like a rectangular wave, the frequency correlates to 2 x rotor speed. At blocked rotor the output signal could be L ( $\leq 0.3V$ ) or H ( $V_{cc}$ ).

**IMPORTANT:** The pulse output is *not* protected against short circuit and must not connect to GND or  $V_{cc}$  without series-resistor. A pull-up-resistor is needed.

Do not connect not used pulse output to GND or  $V_{cc}$  (insolate).

The HYB55C05(A) has tinned lead wire ends (without connector).

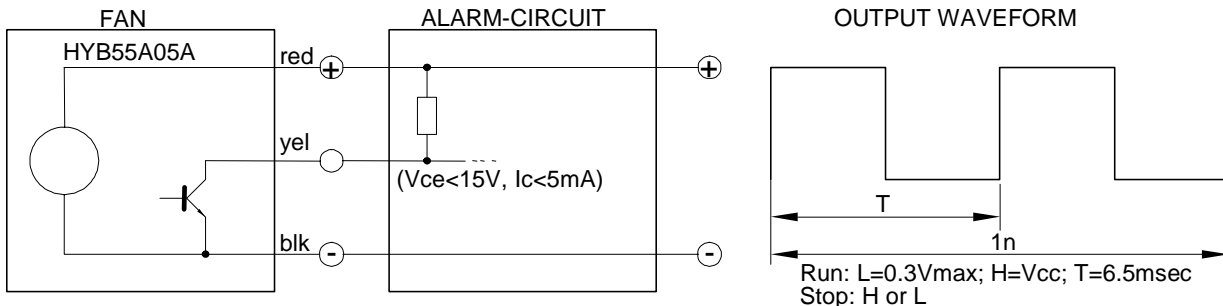

**IMPORTANT:** Only hold the fan at the outer edge and do not touch the impeller!

• **Accessories:**

ALG01 **SEPA** ALARM, monitor-circuit, generates an acoustic signal in case of missing pulses.  
CONNECTOR on request

• **Order information:**

HYB55A05	<b>SEPA</b> fan, 55x55x10.8mm, 5VDC, ball bearings, <b>CE</b>	BPKC1045
HYB55A05A	<b>SEPA</b> fan, 55x55x10.8mm, 5VDC, pulse, ball bearings, <b>CE</b>	BPKL1060