

HYB60A05(A) HYB60A12(A)

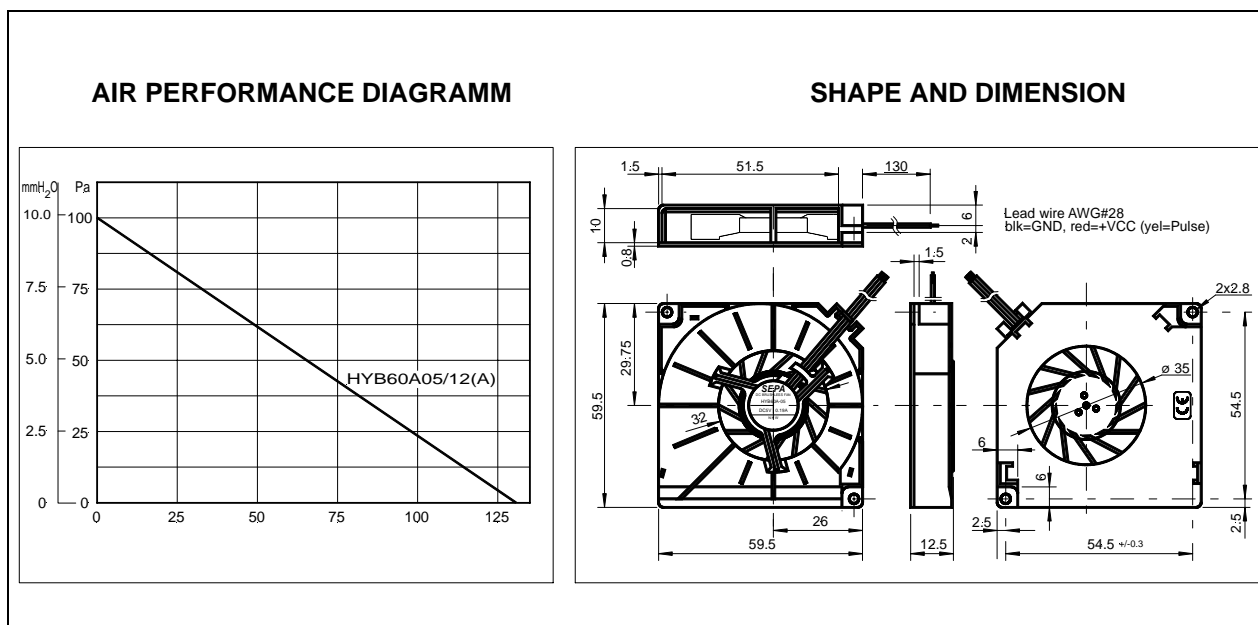

HIGH RELIABILITY FAN

AUTOMOTIVE FAN



PERFORMANCE

CE		HYB60A05(A)	HYB60A12(A)
Operating Voltage	[V]	4.5 ... 5.0 ... 5.5	10.8 ... 12 ... 13.8
Operating Current	[mA]	190	90
Max. Start Current	[mA]	330	200
Max. Air Flow	[l/min - m ³ /h]	130 – 7.80	132 – 7.92
Max. Air Pressure	[mmH ₂ O - Pa]	9.5 – 93.3	10.0 – 98.5
Noise @ 1m (typ.)	[dB(A)]	32	32
Operating Temperature	[°C]	-10/+60 (80)	
Rotor Speed	[RPM]	3750	3800
Life Expectancy @20°C	[L ₁₀ /MTBF; h]	75000/225000	
Bearing System		ball bearing ZZ	
Weight	[g]	22	
Pulse (HYB60AxxA only)		2 pulses / rev.	2 pulses / rev.
Packing Quantity	[PCs]	50-500	

This **SEPA**[®] turbo fan is suitable for industrial use and has a remarkable air flow performance despite its extremely small dimensions. Due to the linear air performance characteristic, the fan is applicable for different uses. Air intake could be on top or bottom, the outlet is on one side. It is permanently protected electrically against reverse polarity, blocking and thermal overloading. Due to the low rotor weight and precision balancing, it is virtually vibration-free. It is also insensitive to shock.

Further features of this fan are its extremely robust and torsionally rigid housing made from BPT with 30% fibreglass and aluminium base plate, ball bearings with narrow tolerances, of special steel, polyester-based PCB (UL E44247) and absolute reliability due to 100% burn-in.

• **Alarm Signal (Optional)**

The **SEPA**® HYB60AxxA include a speed impulse output, which enables monitoring the correct function of the fan. An alarm-board is available on request.

The pulse is like a rectangular wave, the frequency correlates to 2 x rotor speed. At blocked rotor the output signal could be L ($\leq 0.3V$) or H (V_{cc}).

IMPORTANT: The pulse output is *not* protected against short circuit and must not connect to GND or V_{cc} without series-resistor. A pull-up-resistor is permitted.

Do not connect pulse output wire to GND or V_{cc} (insolate).

The HYB60Axx(A) have tinned lead wire ends (without connector).

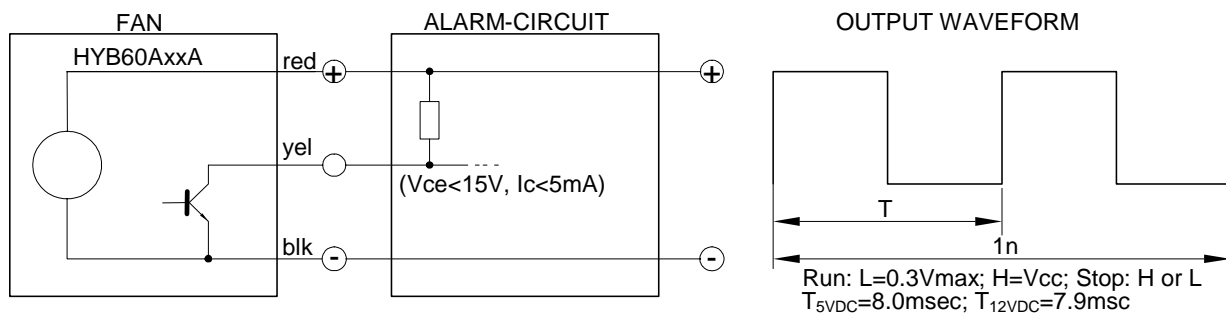

IMPORTANT: Do not touch the impeller!

• **Accessories:**

ALG01 **SEPA** ALARM, monitor-circuit, generates an acoustic signal in case of missing pulses.
CONNECTOR on request

• **Order information:**

HYB60A05	SEPA fan, 60x60x12.5mm, 5VDC, ball bearing, CE	BPKL1061
HYB60A05A	SEPA fan, 65x60x12.5mm, 5VDC, pulse, ball bearing, CE	BPKL1062
HYB60A12	SEPA fan, 60x60x12.5mm, 12VDC, ball bearing, CE	BPKL1063
HYB60A12A	SEPA fan, 65x60x12.5mm, 12VDC, pulse, ball bearing, CE	BPKL1064